

# security labs

## 16 Channel Multiplexed DVR

Model SLD260



## Owner's Manual

15540 Herriman Blvd. Noblesville, IN 46060 - Customer Support 1-800-774-0284

[www.security-labs.com](http://www.security-labs.com)

# Table of Contents

## 1. Introduction

1-1 Safety Warning .....	3
1-2 Features .....	4
1-3 Specifications .....	5

## 2. Installation

2-1 Package contents .....	6
2-2 Connection .....	6
2-3 Rack mount installation .....	7
2-4 RS232 /RS485 Remote protocol .....	8

## 3. Configuration

3-1 Install HDD .....	9
3-2 Front panel keypad .....	11
3-3 Back panel connection .....	13
3-4 Menu setup .....	19
3-5 System setup .....	19
3-6 Search setup .....	25
3-7 Timer setup (Schedule Time-Lapse record mode setup).....	27
3-8 Record Setup .....	29
3-9 Camera setup .....	31
3-10 Motion Detection setup .....	33
3-11 Event .....	36

## 4. Operation

4-1 Power on .....	37
4-2 Recording .....	37
4-3 Camera Select (1-16) .....	38
4-4 Select.....	38
4-5 Picture in Picture.....	39
4-6 Zoom .....	39
4-7 Play .....	39
4-8 Video Loss .....	40
4-9 Key Lock .....	40

## 5. Trouble shooting & appendix

5-1 Trouble shooting .....	41
5-2 Compatible HDD brands .....	42

# 1. Introduction

Thank you for choosing this high quality Digital Multiplex Recorder. The DMR converts analog NTSC or PAL video to digital images and records them to a removable hard disk drive. Digitally recorded video has many advantages compared to analog video recorded on tape. There is no need to adjust tracking. Digital video can be indexed by time schedule or events, and you can instantly view video after selecting the time or event. You can freeze frames, fast-forward, fast-reverse, slow-forward, and slow-reverse without image streaking or tearing. It can be used as a replacement for both a time-lapse VCR and a multiplexer in a security installation.

## **1.1 Safety Warning**

***All the safety and operating guidelines should be read prior to operation. Improper operation may cause permanent damage to the unit.***

- 1.1.1 Use the provided adaptor.
- 1.1.2 Lift and place this equipment gently.
- 1.1.3 Do not expose this equipment to open sunlight.
- 1.1.4 Do not use this equipment near water or in contact with water.
- 1.1.5 Do not spill liquid of any kind on the equipment.
- 1.1.6 Power down the unit before unplugging.
- 1.1.7 This equipment should be operated only with the power source from the standard package.
- 1.1.8 Unauthorized repairs or part substitutions may result in fire, electric shock or other hazards.
- 1.1.9 Do not switch the Power On & Off within a short period of time (within 3 seconds).
- 1.1.10 Do not attempt to service this equipment yourself. Refer all servicing and repair to qualified service personnel.
- 1.1.11 This unit should be operated only from the power source indicated on the manufacturer's label.
- 1.1.12 Installation should be made by qualified service personnel and should conform to all local safety codes and regulations.

## 1.2 Features

1.2.1 Wavelet Compression Format replaces Time-Lapse VCR + Multiplexer

1.2.2 Four Audio inputs / Two Audio outputs

1.2.3 On Screen Display and RTC (Real time clock) Function

1.2.4 Multiplexing

- ✍ Support from 4 channels up to 7, 9, 10, 13 and 16 channels.
- ✍ 16 channels can record or display real-time recorded images.
- ✍ 16 channels with a loop out terminal.

1.2.5 Resolution

Screen Modes	Resolution
Full screen	704(H) x 468(V) <NTSC> / 704(H) x 564(V) <PAL>
4 channels	352(H) x 234(V) <NTSC> / 352(H) x 282(V) <PAL>
9 channels	224(H) x 156(V) <NTSC> / 224(H) x 188(V) <PAL>
16 channels	176(H) x 117(V) <NTSC> / 176(H) x 141(V) <PAL>

1.2.6 Independent main and call monitor outputs allow simultaneous multi-camera or full screen viewing.

1.2.7 Multi Screen Display Mode

- ✍ Shown below are optional display modes during surveillance & DMR play back:

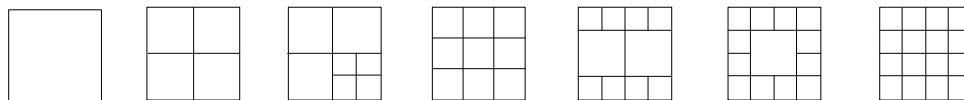

Full Screen

Quad

7 CH

9 CH

10 CH

13 CH

16 CH

1.2.8 Picture-In-Picture (PIP) is available in live and DMR playback modes. Offers Zoom capability up to 2 X 2 in live and DMR playback modes

1.2.9 16 channels are swappable and each channel has an independent title generator (up to 6 characters).

1.2.10 Motion detection uses 15x12 target (NTSC) or 15x14 target (PAL) motion detection grids for each video channel.

1.2.11 Video Quality Adjustable on Each Channel

1.2.12 Alarm Input Function & Output Function

1.2.13 16 channel alarm input, ALARM display and one alarm output.

1.2.14 Power-loss memory function: set up parameter will remain, in case of power failure.

1.2.15 Call Monitor: Switch Display

1.2.16 Support 2 Removable HDD, IDE Type

1.2.17 Timer: Schedule recording

1.2.18 Display refresh rate up to 72 IPS (60 IPS for PAL)

1.2.19 Record refresh rate up to 25 IPS (18 IPS for PAL)

1.2.20 Quick Multiple Search by date/time, alarm and full list

1.2.21 Fast and slow playback in multiple speeds.

1.2.22 Security password protection

1.2.23 RS-232 and RS-485 communication protocol

### 1.3 Specifications

DMS-MBR 1.0

<b>Video format</b>	NTSC/EIA or PAL/CCIR
<b>Hard disk storage</b>	IDE type, UTMA 66 above, 2 removable HDDs supported
<b>Record mode</b>	Manual / Alarm / Timer
<b>Camera Input Signal</b>	Composite video signal 1 Vp-p 750 BNC, 16 channels
<b>Camera Loop Back</b>	Composite video signal 1 Vp-p 750 BNC, 16 channels
<b>Main Monitor Output</b>	Composite video signal 1 Vp-p 750 BNC
<b>Call Monitor Output</b>	Composite video signal 1 Vp-p 750 BNC
<b>Audio input</b>	4 audio inputs, (RCA)
<b>Audio output</b>	2 audio outputs, (RCA)
<b>Motion Detect Area</b>	15 * 12 targets per camera (NTSC) / 15 * 14 targets per camera (PAL)
<b>Motion Detect Sensitivity</b>	256 Levels
<b>Video Loss Detection</b>	Yes
<b>Refresh Rate</b>	72 images/sec. for NTSC / 60 images/sec. for PAL
<b>Recording Rate</b>	25 images/sec. for NTSC / 18 images/sec. for PAL
<b>Dwell Time</b>	Programmable (1~10 Sec)
<b>Picture in Picture</b>	Yes (Movable)
<b>Key Lock</b>	Yes
<b>Picture Zoom</b>	2*2 (Movable)
<b>Camera Title</b>	6 letters
<b>Video Adjustable</b>	Color/ Contrast/ Brightness Adjustable
<b>Alarm Input</b>	TTL input, Hi (5V), Low (GND)
<b>Alarm Output</b>	N.O. (Normally Open) Relay contact 24V / 2Amp Max.
<b>Remote Control</b>	RS-232 or RS-485
<b>Time Display Format</b>	YY/MM/DD, DD/MM/YY, MM/DD/YY, OFF
<b>Power Source</b>	AC100~240V $\pm$ 10% switching adaptor
<b>Power Consumption</b>	<45W
<b>Operation Temperature</b>	10 ~ 40?
<b>RS-232C / RS-485 (bps)</b>	115200? 57600? 19200? 9600? 4800? 3600? 2400? 1200
<b>Dimension (mm)</b>	432(W) x 110(H) x 325(D)
<b>Net Weight</b>	5.7 kgs

Specifications are subject to change without notice.

## 2. Installation

### 2.1 Package contents

The package contains the following items.

- ✂ Digital Multiplex Recorder
- ✂ HDD cartridge
- ✂ Key for cartridge (Inside of HDD cartridge)
- ✂ Power cord
- ✂ User manual
- ✂ Rack mounting kit (Optional)

### 2.2 Connection

#### 2.2.1 Connect with cameras

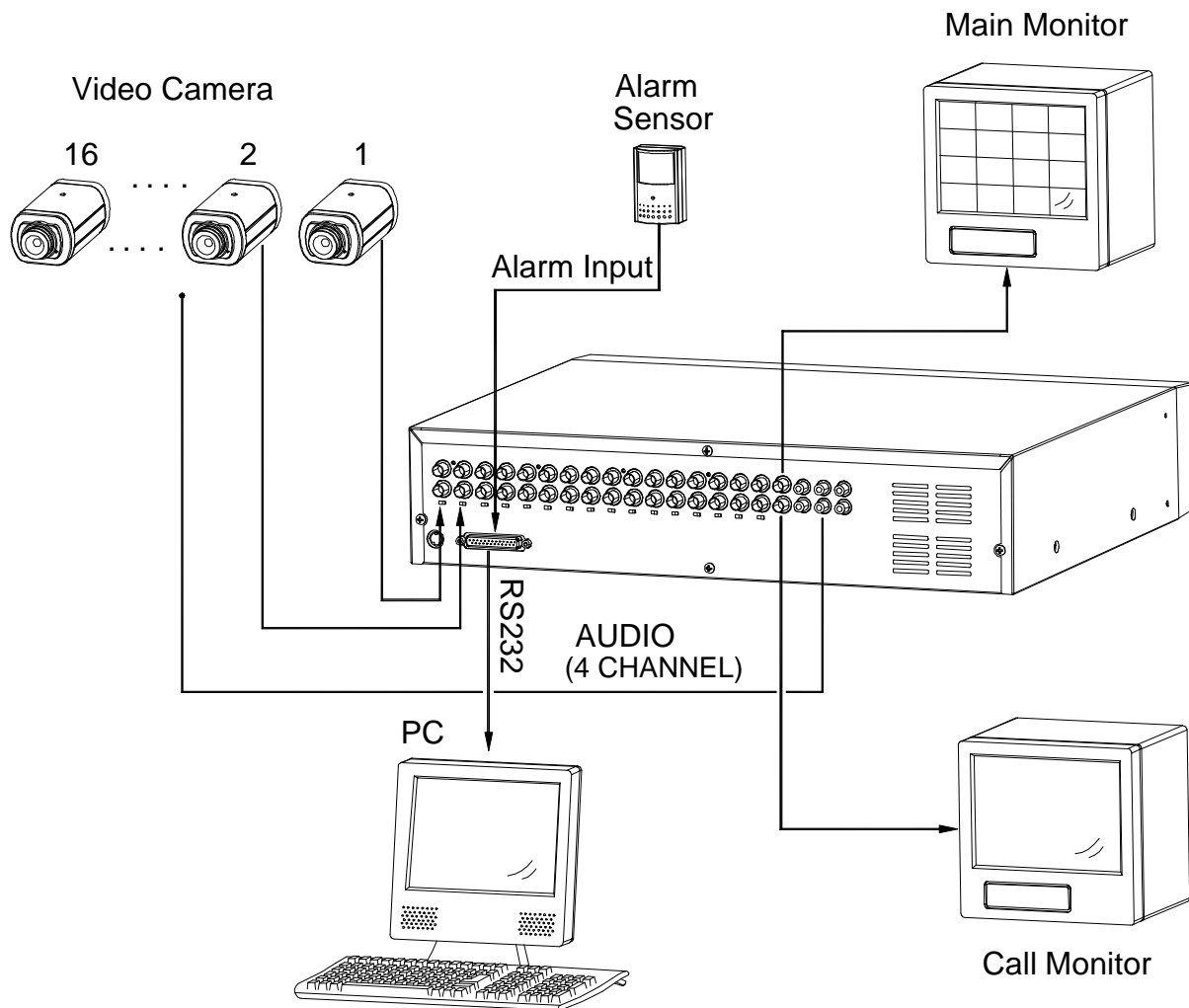

**2.3 Rack mount installation**

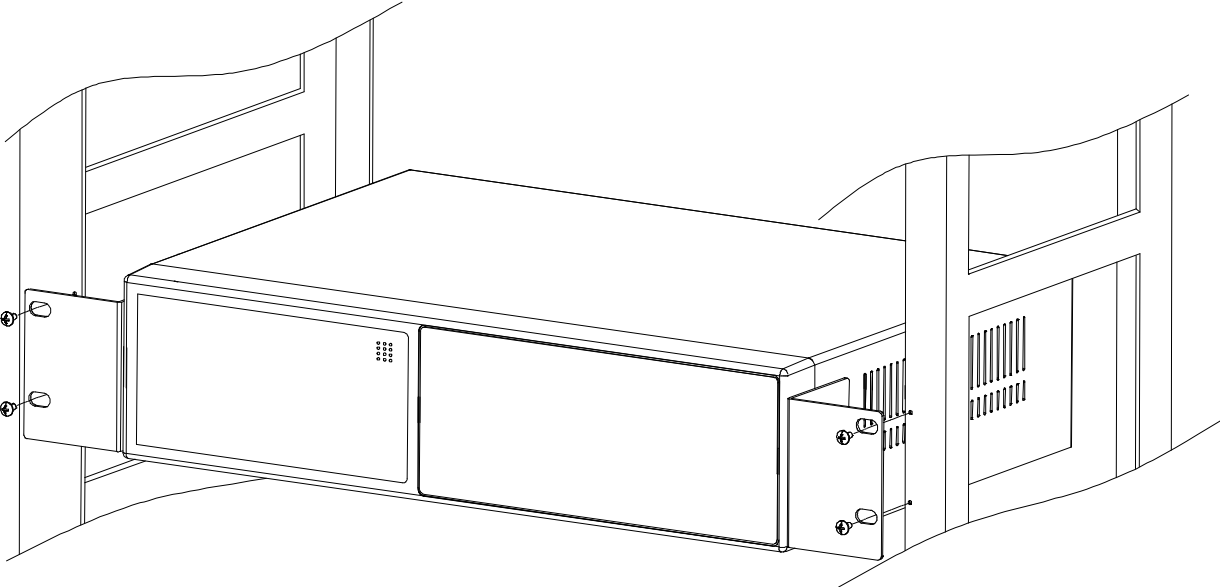

Front Angle with Rack Mount

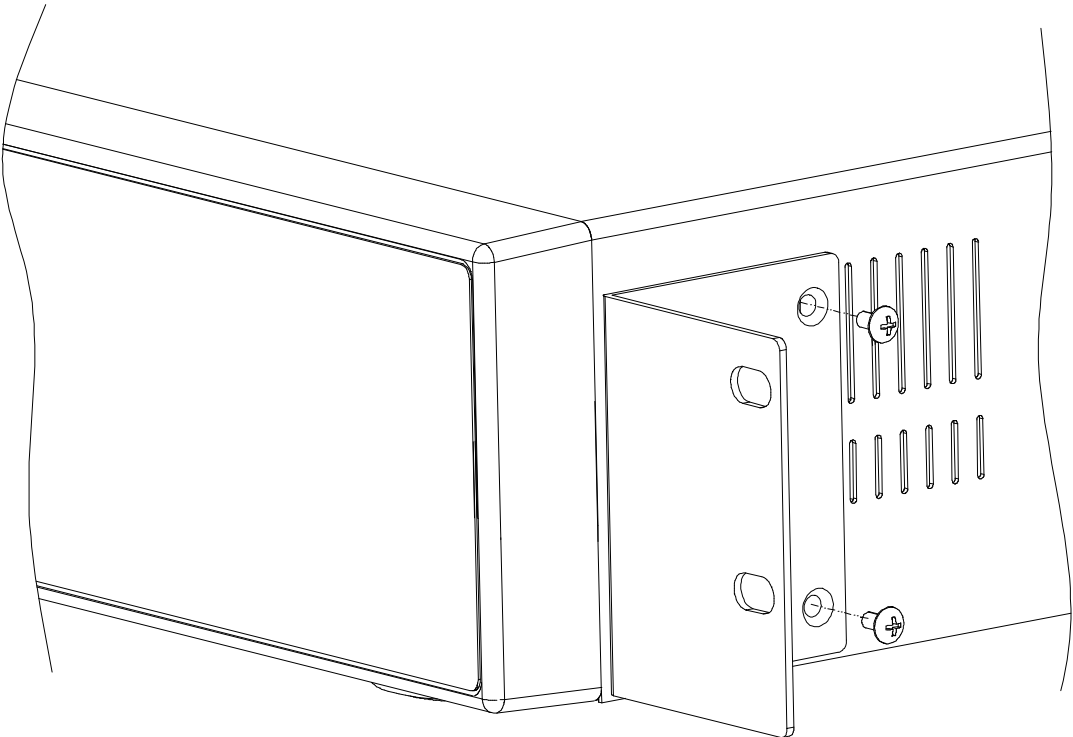

Side View with Rack Mount

## 2.4 RS232 Remote Protocol

You can use a PC keyboard to simulate a DMR keypad.

DATA: REMOTE PROTOCOL using 8 bit data? 1 start bit? 1 stop bit

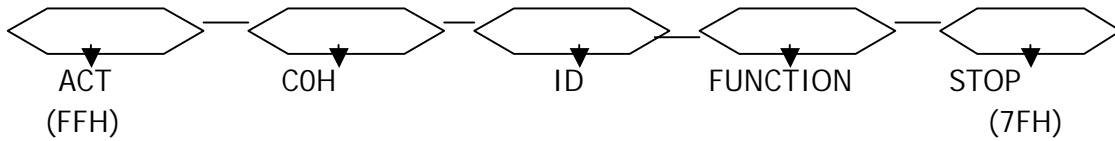

FUNCTION	CODE	ASCII	FUNCTION	CODE	ASCII
KEY_MENU	0x4D	M	KEY_CH1	0x31	1
KEY_SELECT	0x73	s	KEY_CH2	0x32	2
KEY_ENTER	0x0D	ENTER	KEY_CH3	0x33	3
KEY_4CUT	0x61	a	KEY_CH4	0x34	4
KEY_ZOOM	0x5A	Z	KEY_CH5	0x35	5
KEY_9CUT	0x62	b	KEY_CH6	0x36	6
KEY_PIP	0x70	p	KEY_CH7	0x37	7
KEY_16CUT	0x63	c	KEY_CH8	0x38	8
KEY_SLOW	0x53	S	KEY_CH9	0x39	9
KEY_REC	0x72	r	KEY_CH10	0x41	A
KEY_LEFT	0x4C	L	KEY_CH11	0x42	B
KEY_UP	0x55	U	KEY_CH12	0x43	C
KEY_PLAY	0x50	P	KEY_CH13	0x44	D
KEY_DOWN	0x4E	N	KEY_CH14	0x45	E
KEY_RIGHT	0x52	R	KEY_CH15	0x46	F
KEY_POWER	0x57	W	KEY_CH16	0x47	G
KEY_KEY_LOCK	0x4B	K			

## 3. Configuration

### 3.1 Installing the HDD

#### 3.1.1 Installing Hard Drive into Cartridge

- 3.1.1.1. Please find the drawer Key in the extra tray.
- 3.1.1.2. Push the front cover of the HDD cartridge back and use the miniature key provided and insert into the keyhole, turning the key counter-clockwise.
- 3.1.1.3. Pull the handle outwards to remove the tray from the cartridge frame.
- 3.1.1.4. Push the open button to slide the top cover backwards and remove.
- 3.1.1.5. Insert the DC power cable and IDE cable into the HDD.
- 3.1.1.6. Position the HDD into the carrier body and secure the HDD with the four #6/32 screws provided.
- 3.1.1.7. Slide the top cover back over the tray by sliding it forward to secure.
- 3.1.1.8. Slide the tray back into the cartridge frame.

#### 3.1.2 Function Settings and Operation

##### 3.1.2.1 Power Indicator and HDD Access indicator

When power is on, the indicator will display the following:

Item	Indicator
Power Indicator	Green LED
HDD Access Indicator	Yellow LED

#### 3.1.3 Key lock

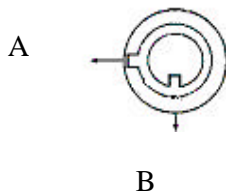

Status	Power status	Security status
Segment A	ON	Locked (Irremovable)
Segment B	OFF	Unlocked (Removable)

**You must turn the key lock to the “A” position before powering on the unit. Otherwise the HDD will not operate properly.**

3.1.4 If two HDDs are to be used, one should be selected as “ Master “ and the other should be selected as “ Slave”. Otherwise, please set the jumpers on the two HDDs to Cable Select (CS).

3.1.1.1 This product does not support hot swap. Please power off the unit first before removing the HDD.

3.1.1.2 The models and manufactures of the HDDs listed in the back of this manual have been tested and proven compatible with this unit.

**3.1.1.3 Please remove the hard disk drive ONLY after the power has been shut off for more than 60 seconds. This will protect and extend the operating life of the hard disk drive.**

3.1.1.4 Master or Slave HDD should be determined before installing new HDD(s).

3.1.1.5 Cable Select (CS) is recommended for the jumper on the back of the new HDD.

3.1.4 Total recording time varies depending on Record Speed, Record Quality, and size of HDD selected.

Please refer to following table.

#### NTSC SYSTEM

IPS		25A	15	8	4	2	1
Record Quality	Best	48hr	96hr	180hr	360hr	720hr	1440hr
	High	60hr	120hr	226hr	450hr	900hr	1800hr
	Normal	96hr	192hr	360hr	720hr	1440hr	2880hr
	Basic	160hr	320hr	600hr	1200hr	2400hr	4800hr
HDD Type		240GB					

#### PAL SYSTEM

IPS		18A	12	6	3	2	1
Record Quality	Best	48hr	100hr	202hr	406hr	608hr	1216hr
	High	60hr	126hr	254hr	506hr	760hr	1520hr
	Normal	98hr	202hr	406hr	810hr	1216hr	2440hr
	Basic	162hr	336hr	676hr	1350hr	2026hr	4050hr
HDD Type		240GB					

**Note: Above data is from actual test data obtained from recording a normal TV program. (Reference only)**

### 3.2 Front panel keypad

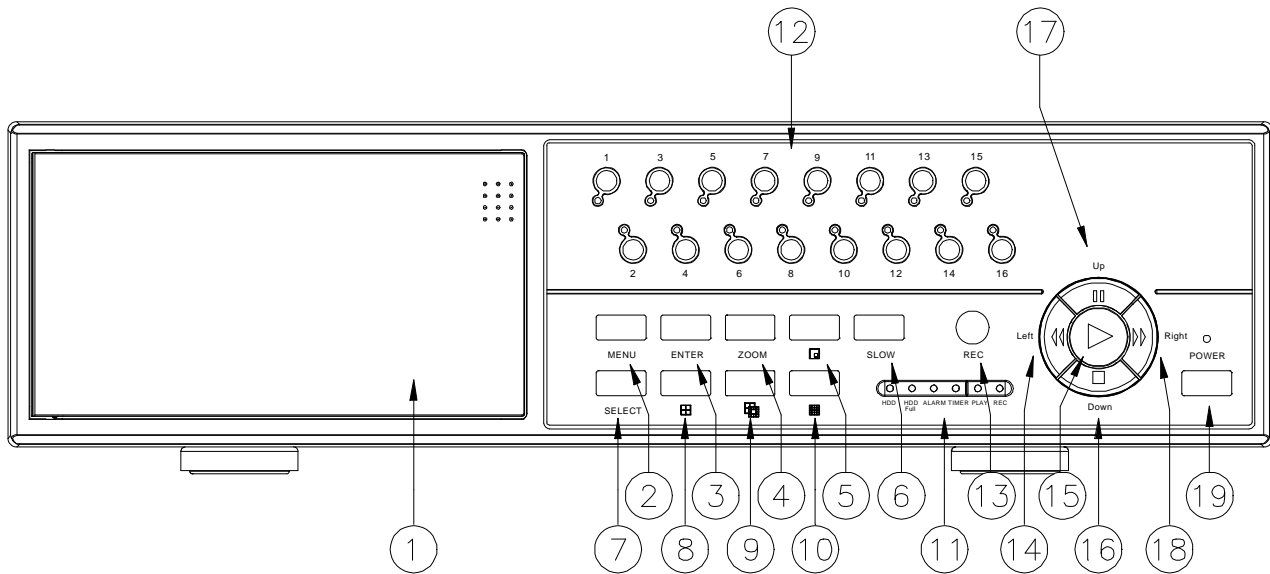





Please follow the instructions below for proper operation of this unit.

#### 1. Install HDD

This device comes equipped with a removable hard disk drive tray. Before turning on this device, you must install the hard disk drive (unless already included), and prepare it for operation.

If two HDDs are to be set up, one should be selected as “Master” and the other should be selected as “Slave”. Otherwise, please set the jumpers on both HDDs to Cable Select (CS).

2. **MENU:** Press **MENU** to enter main menu operation mode, and enter administrator password (default:0000) to access main menu.
3. **ENTER:** Press **ENTER** for confirmation.
4. **ZOOM:** Press the **ZOOM** button to enlarge the main monitor picture display.
5.  : Picture in Picture. Press PIP button to enter PIP display screen.
6. **SLOW:** Press **SLOW** to slow down speed of play mode.
7. **Select:** Press Select to choose the camera (1~16) to display in full screen mode.
8.  : 4 channel display mode
9.  : 7, 9, 10, and 13 channel display mode
10.  : 16 channel display mode
11. **LED Light:** Under the following conditions, the LED Light remains ON.
  - (1) HDD: HDD is activated
  - (2) HDD Full: HDD is full

(3) ALARM: When Alarm is Enabled: Yes (when the alarm is triggered, the led flashes)

(4) TIMER: When Timer is Enabled: Yes

(5) PLAY: Play operation

(6) REC: Recording operation

**12. CAMERA (1-16):** Press the **Camera Select (1-16)** to choose a camera.

**13. REC:** Press **REC** to start recording.

**14. REW / Left:**

**REW:** Under DMR play mode, it can play video backwards at a high speed. Press REW again to select the speed (1x, 2x, 4x, 8x, 16x, 32x).

**Left:** Under setup mode, it works as the **Left** button.

**15. PLAY:** Press **PLAY** to play recorded video.

**16. STOP / Down:**

**STOP:** Under DMR Record/Play mode, it stops recording and playing video.

**Down:** Under setup mode, it works as the **Down** button.

**17. PAUSE / Up:**

**Pause:** Under DMR play mode, it pauses played video.

**Up:** Under setup mode, it works as the **Up** button.

**18. FF / Right:**

**FF:** Under DMR play mode, it plays video forward at a high speed. Press **FF** again to select the speed (1x, 2x, 4x, 8x, 16x, 32x).

**Right:** Under setup mode, it works as the **Right** button.

**19. POWER:** To power on, press the power button.

To power off, press the power button again.

**Note:** After 60 seconds of suspended operation, the function setup will be turned off automatically.

### **3.3 Back panel connection**

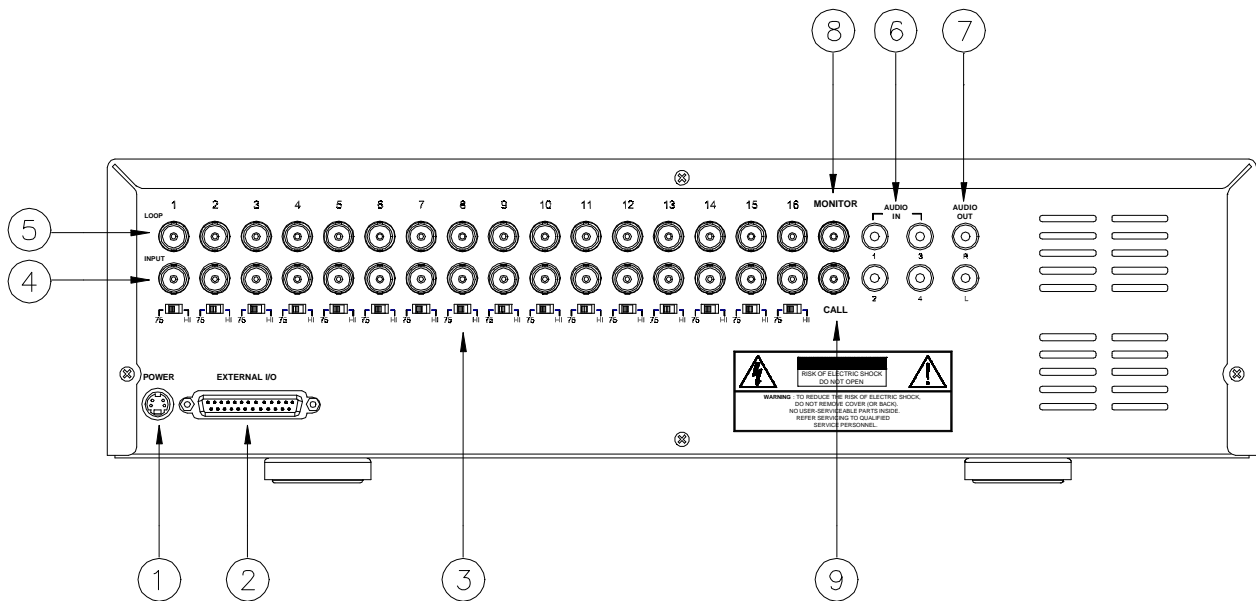

### 3.3.1 Power input

Please use only the provided power adaptor.

### 3.3.2 External I/O

Controlled remotely by an external device or control system.

Alarm input, external I/O explanation.

### 3.3.3 75 / HI

When using the Loop function, please switch to **HI** or **75 (Ohm)**.

### 3.3.4 VIDEO INPUT (1-16)

Connects to a video source, such as a camera.

### 3.3.5 Loop

Outputs the video signal from that channel to another device if needed.

### 3.3.6 AUDIO IN (1-4)

Connects to an audio source, such as a microphone.

\* **IPS (Record Menu – Images Per Second) should be set to 25A (for NTSC) or 18A (for PAL)**

### 3.3.7 AUDIO OUT (R/L)

Connects to a monitor or speaker.

\* **IPS should be set to 25A (for NTSC) or 18A (for PAL)**

### 3.3.8 MONITOR

Connects to a Main monitor.

### 3.3.9 CALL

3.3.10 Connects to a CALL monitor. Show the Switch Display.

## 3.3.9 External I/O

## 25 pin com port

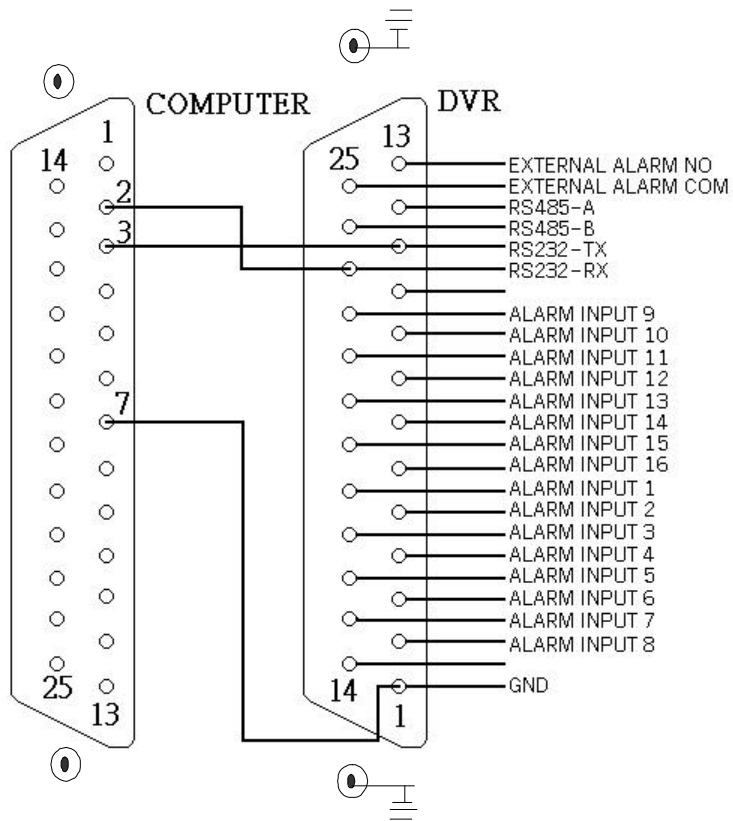

## 9 pin com port

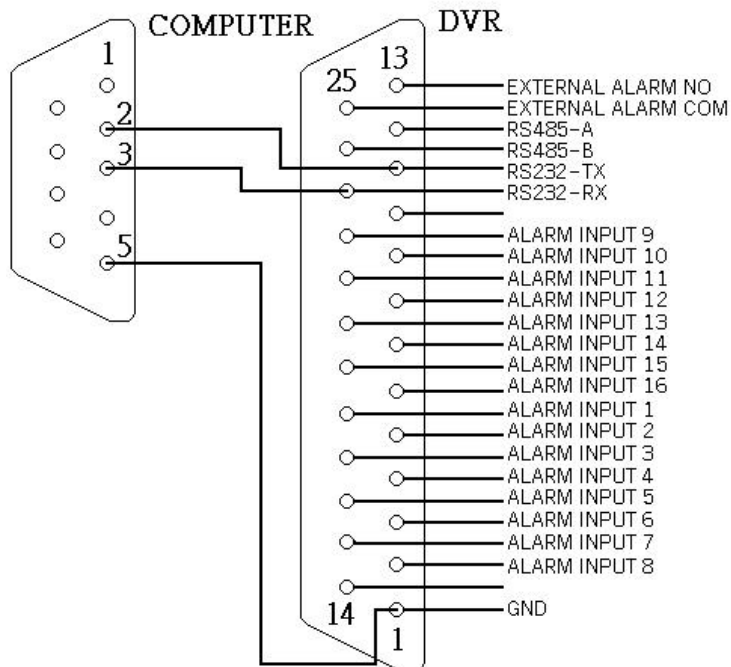

**PIN 1. GND**

## GROUND

### **PIN 2. ALARM INPUT 8**

Connect a wire from **ALARM INPUT 8 (PIN 2)** to **GND (PIN 1)** connector, DMR will start recording and the buzzer will activate.

Menu/ Camera/ Alarm is set to “Low”: When the alarm input signal is “Low”, the unit starts to record and the buzzer will activate.

Menu/ Camera/ Alarm is set to “High”: When the alarm input signal is “High”, the unit starts to record and the buzzer will activate.

### **PIN 3. ALARM INPUT 6**

Connect a wire from **ALARM INPUT 6 (PIN 3)** to **GND (PIN 1)** connector, DMR will start recording and the buzzer will activate. .

Menu/ Camera/ Alarm is set to “Low”: When the alarm input signal is “Low”, the unit starts to record and the buzzer will activate.

Menu/ Camera/ Alarm is set to “High”: When the alarm input signal is “High”, the unit starts to record and the buzzer will activate.

### **PIN 4. ALARM INPUT 4**

Connect a wire from **ALARM INPUT 4 (PIN 4)** to **GND (PIN 1)** connector, DMR will start recording and the buzzer will activate.

Menu/ Camera/ Alarm is set to “Low”: When the alarm input signal is “Low”, the unit starts to record and the buzzer will activate.

Menu/ Camera/ Alarm is set to “High”: When the alarm input signal is “High”, the unit starts to record and the buzzer will activate.

### **PIN 5. ALARM INPUT 2**

Connect a wire from **ALARM INPUT 2 (PIN 5)** to **GND (PIN 1)** connector, DMR will start recording and the buzzer will activate. .

Menu/ Camera/ Alarm is set to “Low”: When the alarm input signal is “Low”, the unit starts to record and the buzzer will activate.

Menu/ Camera/ Alarm is set to “High”: When the alarm input signal is “High”, the unit starts to record and the buzzer will activate.

### **PIN 6. ALARM INPUT 16**

Connect a wire from **ALARM INPUT 16 (PIN 6)** to **GND (PIN 1)** connector, DMR will start recording and the buzzer will activate. .

Menu/ Camera/ Alarm is set to “Low”: When the alarm input signal is “Low”, the unit starts to record and the buzzer will activate.

Menu/ Camera/ Alarm is set to “High”: When the alarm input signal is “High”,

the unit starts to record and the buzzer will activate.

**PIN 7. ALARM INPUT 14**

Connect a wire from **ALARM INPUT 14 (PIN 7)** to **GND (PIN 1)** connector, DMR will start recording and the buzzer will activate. .

Menu/ Camera/ Alarm is set to “Low”: When the alarm input signal is “Low”, the unit starts to record and the buzzer will activate.

Menu/ Camera/ Alarm is set to “High”: When the alarm input signal is “High”, the unit starts to record and the buzzer will activate.

**PIN 8. ALARM INPUT 12**

Connect a wire from **ALARM INPUT 12 (PIN 8)** to **GND (PIN 1)** connector, DMR will start recording and the buzzer will activate.

Menu/ Camera/ Alarm is set to “Low”: When the alarm input signal is “Low”, the unit starts to record and the buzzer will activate.

Menu/ Camera/ Alarm is set to “High”: When the alarm input signal is “High”, the unit starts to record and the buzzer will activate.

**PIN 9. ALARM INPUT 10**

Connect a wire from **ALARM INPUT 10 (PIN 9)** to **GND (PIN 1)** connector, DMR will start recording and the buzzer will activate. .

Menu/ Camera/ Alarm is set to “Low”: When the alarm input signal is “Low”, the unit starts to record and the buzzer will activate.

Menu/ Camera/ Alarm is set to “High”: When the alarm input signal is “High”, the unit starts to record and the buzzer will activate.

**PIN 10. No Connection**

**PIN 11. RS232-TX**

DMR can be controlled remotely by an external device or control system, such as a control keyboard, using RS-232 serial communications signals.

**PIN 12. RS485-A**

DMR can be controlled remotely by an external device or control system, such as a control keyboard, using RS485 serial communications signals.

**PIN 13. EXTERNAL ALARM NO (Normally Open)**

Under normal operation COM is not connected to NO. When an alarm is triggered, COM connects with NO for triggering recommended low voltage accessories.

(Dry relay contact = 24 Volt / 2 Amp Load)

**PIN 14. No connection**

### **PIN 15. ALARM INPUT 7**

Connect a wire from **ALARM INPUT 7 (PIN 15)** to **GND (PIN 1)** connector, DMR will start recording and the buzzer will activate. .

Menu/ Camera/ Alarm is set to “Low”: When the alarm input signal is “Low”, the unit starts to record and the buzzer will activate.

Menu/ Camera/ Alarm is set to “High”: When the alarm input signal is “High”, the unit starts to record and the buzzer will activate.

### **PIN 16. ALARM INPUT 5**

Connect a wire from **ALARM INPUT 5 (PIN 16)** to **GND (PIN 1)** connector, DMR will start recording and the buzzer will activate. .

Menu/ Camera/ Alarm is set to “Low”: When the alarm input signal is “Low”, the unit starts to record and the buzzer will activate.

Menu/ Camera/ Alarm is set to “High”: When the alarm input signal is “High”, the unit starts to record and the buzzer will activate.

### **PIN 17. ALARM INPUT 3**

Connect a wire from **ALARM INPUT 3 (PIN 17)** to **GND (PIN 1)** connector, DMR will start recording and the buzzer will activate. .

Menu/ Camera/ Alarm is set to “Low”: When the alarm input signal is “Low”, the unit starts to record and the buzzer will activate.

Menu/ Camera/ Alarm is set to “High”: When the alarm input signal is “High”, the unit starts to record and the buzzer will activate.

### **PIN 18. ALARM INPUT 1**

Connect a wire from **ALARM INPUT 1 (PIN 18)** to **GND (PIN 1)** connector, DMR will start recording and the buzzer will activate. .

Menu/ Camera/ Alarm is set to “Low”: When the alarm input signal is “Low”, the unit starts to record and the buzzer will activate.

Menu/ Camera/ Alarm is set to “High”: When the alarm input signal is “High”, the unit starts to record and the buzzer will activate.

### **PIN 19. ALARM INPUT 15**

Connect a wire from **ALARM INPUT 15 (PIN 19)** to **GND (PIN 1)** connector, DMR will start recording and the buzzer will activate. .

Menu/ Camera/ Alarm is set to “Low”: When the alarm input signal is “Low”, the unit starts to record and the buzzer will activate.

Menu/ Camera/ Alarm is set to “High”: When the alarm input signal is “High”, the unit starts to record and the buzzer will activate.

#### **PIN 20. ALARM INPUT 13**

Connect a wire from **ALARM INPUT 13 (PIN 20)** to **GND (PIN 1)** connector, DMR will start recording and the buzzer will activate. .

Menu/ Camera/ Alarm is set to “Low”: When the alarm input signal is “Low”, the unit starts to record and the buzzer will activate.

Menu/ Camera/ Alarm is set to “High”: When the alarm input signal is “High”, the unit starts to record and the buzzer will activate.

#### **PIN 21. ALARM INPUT 11**

Connect a wire from **ALARM INPUT 11 (PIN 21)** to **GND (PIN 1)** connector, DMR will start recording and the buzzer will activate. .

Menu/ Camera/ Alarm is set to “Low”: When the alarm input signal is “Low”, the unit starts to record and the buzzer will activate.

Menu/ Camera/ Alarm is set to “High”: When the alarm input signal is “High”, the unit starts to record and the buzzer will activate.

#### **PIN 22. ALARM INPUT 9**

Connect a wire from **ALARM INPUT 9 (PIN 22)** to **GND (PIN 1)** connector, DMR will start recording and the buzzer will activate. .

Menu/ Camera/ Alarm is set to “Low”: When the alarm input signal is “Low”, the unit starts to record and the buzzer will activate.

Menu/ Camera/ Alarm is set to “High”: When the alarm input signal is “High”, the unit starts to record and the buzzer will activate.

#### **PIN 23. RS232-RX**

A DMR can be controlled remotely by an external device or control system, such as a control keyboard, using RS-232 serial communications signals.

#### **PIN 24. RS485-B**

A DMR can be controlled remotely by an external device or control system, such as a control keyboard, using RS485 serial communications signals.

#### **PIN 25. EXTERNAL ALARM COM (Common)**

Under normal operation COM is not connected to NO. When an alarm is triggered, COM connects with NO for triggering recommended low voltage accessories.

(Dry relay contact = 24 Volt / 2 Amp Load)

### **3.4 Menu setup**

Press **"MENU"** to enter the main menu. You will need to enter a password to access the main menu. Press **"Right"** or **"Left"** to move digits. Then press **"Up"** or **"Down"** to select a number. Press the **"ENTER"** button to confirm the password.

Ex.: Password: 0000 (Default: 0000)



After keying in the correct password, and confirming it by pressing the **"ENTER"** button. The screen on the right will be displayed:

SEARCH ----- Find Recordings  
TIMER ----- Schedule Recording Times  
RECORD----- Record Mode Setup  
CAMERA ----- Camera Channel Setup  
SYSTEM ----- System Setup  
EVENT ----- Event List

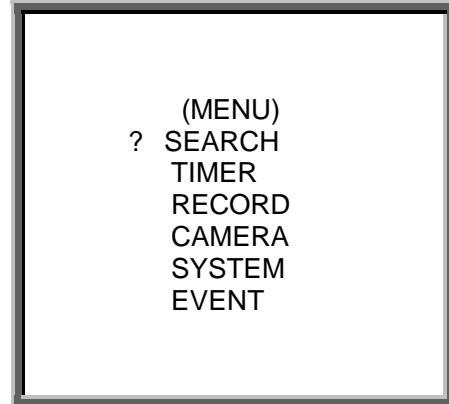

*\*To understand the proper operation of this unit, we must start with an introduction to*

*System setup.*

### **3.5 System setup**

Press **"MENU"** to enter the main menu. You will need to enter the password to access the main menu. Press **"Right"** or **"Left"** to move digits. Then press **"Up"** or **"Down"** to select a number. Press the **"ENTER"** button to confirm the password.

Ex.: PASSWORD: 0000 (Default: 0000)



After keying in the correct password, and confirming it by pressing the **"ENTER"** button. The screen on the right will be displayed:

SEARCH ----- Find Recordings  
TIMER ----- Schedule Recording Times  
RECORD----- Record Mode Setup  
CAMERA ----- Camera Channel Setup  
SYSTEM ----- System Setup  
EVENT ----- Event List

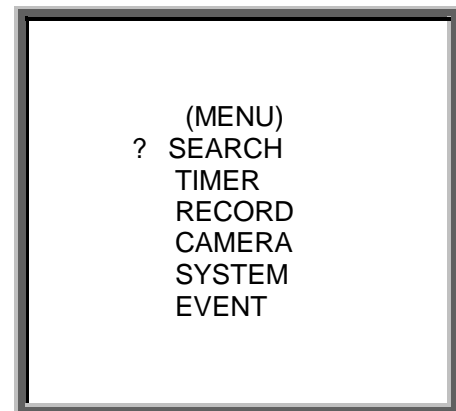

Press "Up" or "Down" to select **SYSTEM** setup

SEARCH  
TIMER  
RECORD  
CAMERA  
? SYSTEM  
EVENT



Press "ENTER" to confirm **SYSTEM** setup, and the screen will display the following options.

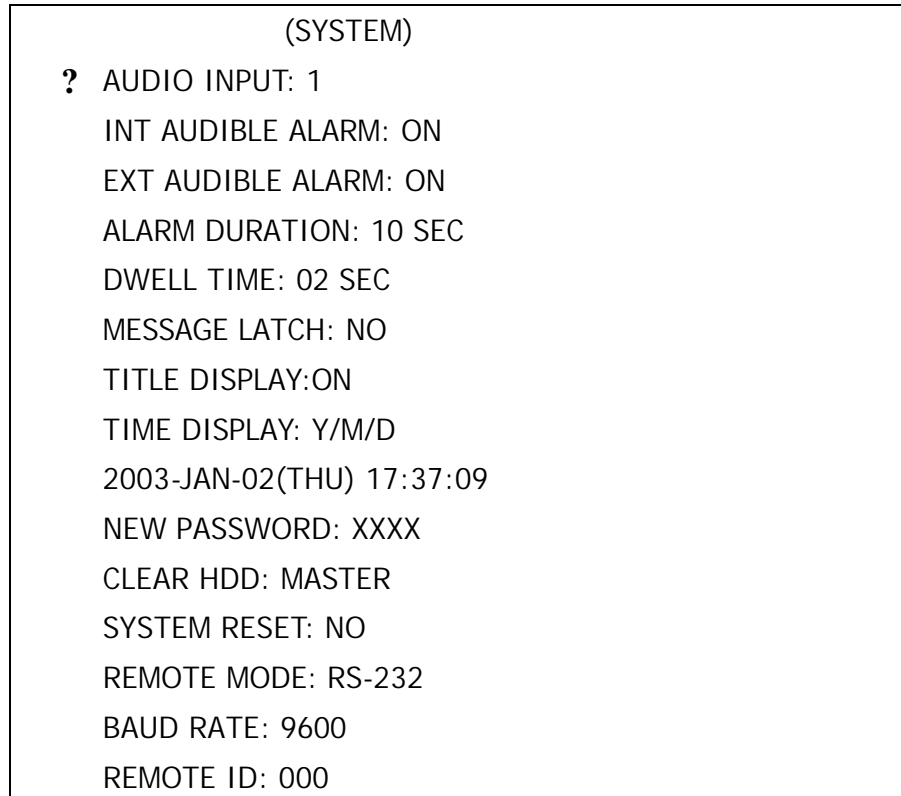

### 3.5.1 AUDIO INPUT setup:

This feature allows the user to set the AUDIO INPUT.

The user can choose 1 of 4 channels to record.

3.5.1.1 Press "Up" or "Down" to choose AUDIO INPUT:

3.5.1.2 Press the "ENTER" button to confirm AUDIO INPUT:

3.5.1.3 Press "Up" or "Down" to choose the AUDIO INPUT: 1~4

3.5.1.4 Press "MENU" to exit and confirm current operation.

3.5.1.5 Press "MENU" again to exit **SYSTEM** setup mode.

### 3.5.2 INT AUDIBLE ALARM setup:

This feature allows the user to set the INTERNAL AUDIBLE ALARM. This alarm will be triggered by an event occurrence when the setting is ON.

3.5.2.1 Press “**Up**” or “**Down**” to choose INT AUDIBLE ALARM

3.5.2.2 Press the “**ENTER**” button to confirm INT AUDIBLE ALARM

3.5.2.3 Press “**Up**” or “**Down**” to choose the INT AUDIBLE ALARM: ON/OFF

ON: Internal Buzzer ON

OFF: Internal Buzzer OFF

3.5.2.4 Press “**MENU**” to exit and confirm current operation.

3.5.2.5 Press “**MENU**” again to exit **SYSTEM** setup mode.

### 3.5.3 EXT AUDIBLE ALARM setup:

This feature allows the user to set an EXTERNAL AUDIBLE ALARM that is connected to Pins 13 and 25 of the DB25 connector on the back panel. This alarm will be triggered by an event occurrence when the setting is ON.

3.5.3.1 Press “**Up**” or “**Down**” to choose EXT AUDIBLE ALARM

3.5.3.2 Press the “**ENTER**” button to confirm EXT AUDIBLE ALARM

3.5.3.3 Press “**Up**” or “**Down**” to choose the EXT AUDIBLE ALARM: ON/OFF

ON: External Buzzer ON

OFF: External Buzzer OFF

3.5.3.4 Press “**MENU**” to exit and confirm current operation.

3.5.3.5 Press “**MENU**” again to exit **SYSTEM** setup mode.

### 3.5.4 ALARM DURATION Setup option:

This feature allows the user to set the ALARM DURATION. Reaction time is determined by how long the alarm mode responds to the buzzer.

3.5.4.1 Press “**Up**” or “**Down**” to choose ALARM DURATION setup.

3.5.4.2 Press “**Enter**” to confirm ALARM DURATION setup.

3.5.4.3 Press “**Up**” or “**Down**” to choose ALARM DURATION setup.

Options: 10 SEC, 15 SEC, 20 SEC, 30 SEC, 1MIN, 2MIN, 3 MIN, 5 MIN, 10 MIN, 15 MIN, 30 MIN, or ALWAYS

3.5.4.4 Press “**MENU**” to exit and confirm current operation.

3.5.4.5 Press “**MENU**” again to exit **SYSTEM** setup mode.

### 3.5.5 DWELL TIME setup

This feature allows the user to set the DWELL TIME. DWELL TIME is the time period that

each channel is sequentially shown on the monitor.

3.5.5.1 Press “**Up**” or “**Down**” to choose DWELL TIME setup.

3.5.5.2 Press “**Enter**” to confirm DWELL TIME setup.

3.5.5.3 Press “**Up**” or “**Down**” to choose DWELL TIME.

Options: 01~10 SEC.

3.5.5.4 Press “**MENU**” to exit and confirm current operation.

3.5.5.5 Press “**MENU**” again to exit **SYSTEM** setup mode.

### 3.5.6 MESSAGE LATCH setup

This feature allows the user to decide if the  External Alarm icon and  audio loss icon will be displayed on the monitor.

3.5.6.1 Press “**Up**” or “**Down**” to choose MESSAGE LATCH setup

3.5.6.2 Press the “**ENTER**” button to confirm MESSAGE LATCH setup

3.6.6.3 Press “**Up**” or “**Down**” to choose the MESSAGE LATCH: ON/OFF

ON: Message latch ON

OFF: Message latch OFF

3.6.6.4 Press “**MENU**” to exit and confirm current operation.

3.6.6.5 Press “**MENU**” again to exit **SYSTEM** setup mode.

### 3.5.7 TITLE DISPLAY setup

This feature allows the user to decide if the title will be displayed on the monitor.

3.6.7.1 Press “**Up**” or “**Down**” to choose TITLE DISPLAY setup

3.6.7.2 Press the “**ENTER**” button to confirm TITLE DISPLAY setup

3.6.7.3 Press “**Up**” or “**Down**” to choose TITLE DISPLAY: ON/OFF

ON: Title Display ON

OFF: Title Display OFF

3.6.7.4 Press “**MENU**” to exit and confirm current operation.

3.6.7.5 Press “**MENU**” again to exit **SYSTEM** setup mode.

### 3.5.8 TIME DISPLAY format setup

This feature allows the user to set the time format on the monitor.

3.5.8.1 Press “**Up**” or “**Down**” to choose TIME DISPLAY setup.

3.5.8.2 Press “**ENTER**” to confirm TIME DISPLAY setup.

3.5.8.3 Press “**Up**” or “**Down**” to choose the TIME DISPLAY.

Options: OFF, Y/M/D, M/D/Y or D/M/Y.

3.5.8.4 Press "**MENU**" to exit and confirm current operation.

3.5.8.5 Press "**MENU**" again to exit **SYSTEM** setup mode.

### 3.5.9 TIME setup:

This feature allows the user to set the time.

3.5.9.1 Press "**Up**" or "**Down**" to choose date display.

3.5.9.2 Press "**ENTER**" to confirm date display.

3.5.9.3 Press "**Up**" or "**Down**" to choose the correct Date & Time. Then press "**Right**" or "**Left**" to move digit locations.

3.5.9.4 Press "**MENU**" to exit and confirm current operation.

3.5.9.5 Press "**MENU**" again to exit **SYSTEM** setup mode.

### 3.5.10 NEW PASSWORD: XXXX setup: (Default password: 0000)

This feature allows the user to set a new password.

3.5.10.1 Press "**Up**" or "**Down**" to choose NEW PASSWORD: XXXX setup.

3.5.10.2 Press "**Enter**" to confirm NEW PASSWORD: XXXX setup.

3.5.10.3 Press "**Up**" or "**Down**" to choose a number. Then press "**Right**" or "**Left**" to move digit location.

3.5.10.4 Press "**MENU**" to exit and confirm current operation.

3.5.10.5 Press "**MENU**" again to exit SYSTEM setup mode.

### 3.5.11 CLEAR HDD setup

This feature allows the user to clear all data on the HDD.

3.5.11.1 Press "**Up**" or "**Down**" to choose CLEAR HDD setup.

3.5.11.2 Press "**Enter**" to confirm CLEAR HDD setup.

3.5.11.3 Press "**Up**" or "**Down**" to choose CLEAR HDD for the MASTER or SLAVE.

The screen will display the following.

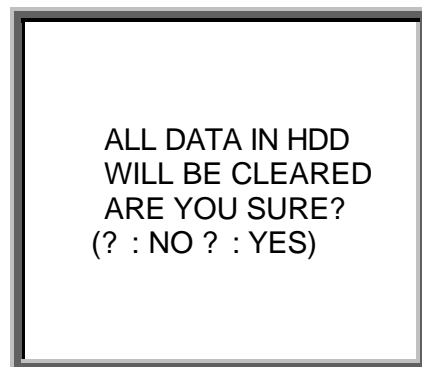

Press“ ? ” to clear HDD

NO: Confirm not to clear HDD.

3.5.11.4 Press “**MENU**” to exit and confirm current operation.

3.5.11.5 Press “**MENU**” again to exit **SYSTEM** setup mode.

### 3.5.12 SYSTEM RESET setup

This feature allows the user to reset the system.

3.5.12.1 Press “**Up**” or “**Down**” to choose SYSTEM RESET setup.

3.5.12.2 Press “**Enter**” to confirm SYSTEM RESET setup.

3.5.12.3 Press “**Up**” or “**Down**” to choose SYSTEM RESET Yes or No.

YES: Confirm to System Reset (load default system settings)

NO: Confirm not to System Reset

3.5.12.4 Press “**MENU**” to exit and confirm current operation.

3.5.12.5 Press “**MENU**” again to exit SYSTEM setup mode.

### 3.5.13 REMOTE MODE setup

This feature allows the user to set the remote mode.

3.5.13.1 Press “**Up**” or “**Down**” to choose REMOTE MODE setup

3.5.13.2 Press “**Enter**” to confirm REMOTE MODE setup

3.5.13.3 Press “**Up**” or “**Down**” to choose Interface for REMOTE MODE setup

RS-232: Use RS-232 interface

RS-485: Use RS-485 interface

3.5.13.4 Press “**MENU**” to exit and confirm current operation.

3.5.13.5 Press “**MENU**” again to exit **SYSTEM** setup mode.

### 3.5.14 Remote protocol Transmitting Baud Rate setup

This feature allows the user to set the remote protocol transmitting baud rate.

3.5.14.1 Press “**Up**” or “**Down**” to choose BAUD RATE setup.

3.5.14.2 Press “**Enter**” to confirm BAUD RATE setup.

3.5.13.3 Press “**Up**” or “**Down**” to choose the BAUD RATE.

Options: 115200, 57600, 19200, 9600, 4800, 3600, 2400, or 1200

3.5.14.4 Press “**MENU**” to exit and confirm current operation.

3.5.14.5 Press “**MENU**” again to exit **SYSTEM** setup mode.

### 3.5.15 Remote protocol ID setup:

This feature allows the user to control different DMR’s by setting the RS232 remote protocol. The ID number can be set from 000 to be 255.

3.5.15.1 Press “Up” or “Down” to choose ID setup.

3.5.14.2 Press “Enter” to confirm ID setup.

3.5.15.3 Press “Up” or “Down” to set the numerical value, from **000** ~ **255**.

3.5.15.4 Press “MENU” to exit and confirm current operation.

3.5.15.5 Press “MENU” again to exit **SYSTEM** setup mode.

### 3.6 **SEARCH** setup

Press “MENU” to enter the main menu. You will need to enter the password to access the main menu. Press “Right” or “Left” to move digits and press **Up** or “Down” to select a number. Press the “ENTER” button to confirm the password.

Ex.: Password: 0000 (Default: 0000)



After keying in the correct password, and confirming it by pressing the “ENTER” button. The screen on the right will be displayed:

SEARCH ----- Find Recordings  
TIMER ----- Schedule Recording Times  
RECORD----- Record Mode Setup  
CAMERA ----- Camera Channel Setup  
SYSTEM ----- System Setup  
EVENT ----- Event List

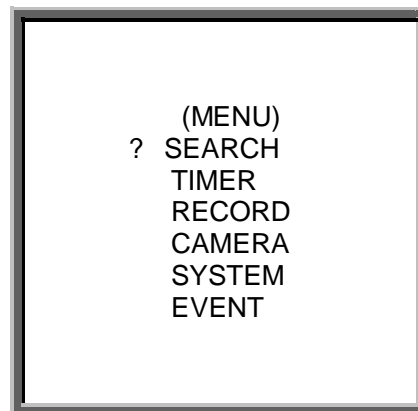

#### 3.6.1 LAST RECORD for recorded video

Press “**Up**” or “**Down**” to choose LAST RECORD. The screen on the right will be displayed. Press “**ENTER**” to confirm LAST RECORD.



### 3.6.2 FULL LIST for recorded video

Press “**Up**” or “**Down**” to choose the Full List item. The screen on the right will be displayed.



Press “**Enter**” to confirm Full List, then the screen on the right will be displayed.  
Press “**Up**” or “**Down**” to choose a recorded event (There will only be 8 listed per page.) to view. Press “**Right**” or “**Left**” to change pages.  
Press “**ENTER**” to Play selected recorded video.

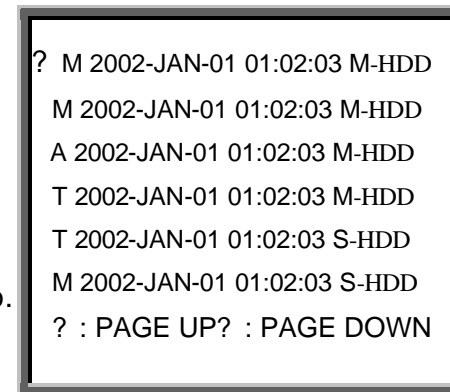

M: Manual Record time

A: Alarm Record time

T: Timer Record time M-HDD:

Storage in Master HDD = M-HDD Storage in Slave HDD = S-HDD

### 3.6.3 ALARM LIST for recorded video

Press “**Up**” or “**Down**” to choose ALARM LIST.  
The screen on the right will be displayed.



Press “**ENTER**” to confirm ALARM LIST, the screen on the right will be displayed.  
Press “**Up**” or “**Down**” to choose a recorded event (There will only be 8 listed per page.) to view. Press “**Left**” or “**Right**” to change pages.  
Press “**ENTER**” to Play selected recorded video.

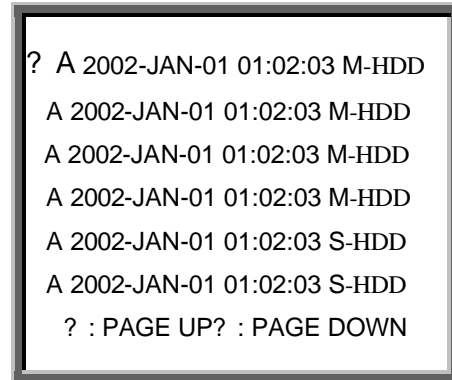

### 3.6.3 TIME SEARCH for recorded video

Press “**Up**” or “**Down**” to choose the Time Search item. The screen on the right will be displayed.



Press “**ENTER**” to confirm Full List, then the screen on the right will be displayed.  
Press “**Up**” or “**Down**” to choose the date & hour of the recorded event. Press “**Left**” or “**Right**” to change the location.  
Press “**ENTER**” to play selected time recorded video. If there is no recording in the database, the screen will display “**NOT FOUND**”.

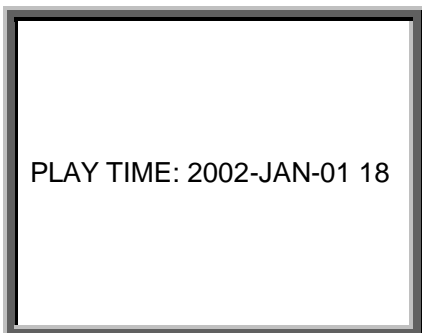

## 3.7 **TIMER setup (Schedule Time-Lapse record mode setup)**

### 3.7.1 Enter TIMER setup

Press “**MENU**” to enter the main menu. You will need to enter the password to access the main menu. Press “**Left**” or “**Right**” to move digits, then press “**Up**” or “**Down**” to select a number. Press the “**ENTER**” button to confirm the password.

Ex.: PASSWORD: 0000 (Default: 0000)



After keying in the correct password, and confirming it by pressing the “**ENTER**” button. The screen on the right will be displayed:

SEARCH ----- Find Recordings  
TIMER ----- Schedule Recording Times  
RECORD----- Record Mode Setup  
CAMERA ----- Camera Channel Setup  
SYSTEM ----- System Setup  
EVENT ----- Event List

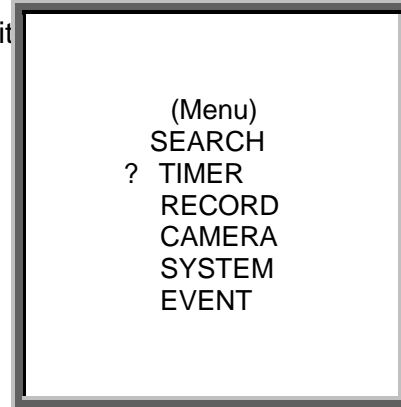

Select **TIMER** , then Press the “**ENTER**” button to confirm **TIMER** Record setup mode. The screen on the right will be displayed.

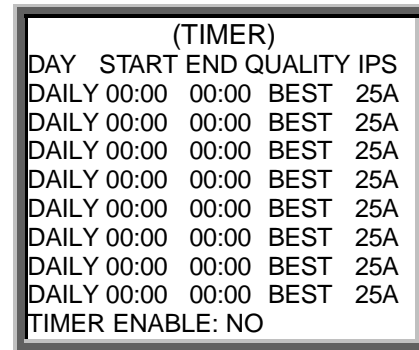

### 3.7.2 TIMER setup:

3.7.2.1 Press “Enter” to confirm **TIMER** setup.

3.7.2.2 Press “Up” or “Down” to choose the Timer Record day

Daily: Everyday

MON: Monday

TUE: Tuesday

WED: Wednesday

THU: Thursday

FRI: Friday

SAT: Saturday

SUN: Sunday

MO-FR: Monday to Friday

SA-SU: Saturday & Sunday

JAN-01: Special Date

OFF: Not activated

3.7.2.3 Press “Left” or “Right” move to START record time 00:00 (HH:MM)

Press “Up” or “Down” to change START record time numerical digit

3.7.2.4 Press “Left” or “Right” move to END record time 00:00 (HH:MM)

Press “Up” or “Down” to change END record Time numerical digit

3.7.2.5 Press “Left” or “Right” move to QUALITY

Press “Up” or “Down” to choose options of  
BEST, HIGH, NORMAL, BASIC

3.7.2.6 Press “Left” or “Right” move to Record IPS (Images Per Second)

Press “Up” or “Down” to choose options of

NTSC- 25A, 15, 8, 4, 2, or 1

PAL- 18A, 12, 6, 3, 2, or 1

3.7.2.7 Press ”**MENU**” to confirm current operation, and enter to next Timer Record setup.

3.7.2.8 Press “Up” or “Down” move location to Timer Enable: Yes or No setup

YES: To confirm Timer Enable: Scheduling Timer Record function

NO: To confirm no Timer Enable: No Scheduling Timer Record function

3.7.2.9 Press “MENU” to exit and confirm current operation.

3.7.2.10 Press “MENU” again to exit and close TIMER setup mode.

### **3.8 RECORD setup**

3.8.1 To Enter “ Record “ setup

Press ”**MENU**” to enter the main menu. You will need to enter the password to access the main menu. Press “Left” or “Right” to move digit, and Press “Up” or “Down” to select number. Press “Enter” button to confirm password.

Ex.: PASSWORD: 0000 (Default: 0000)



After keying in the correct password, and confirming it by pressing the “ENTER” button. The screen on the right will be displayed:

SEARCH ----- Find Recordings  
TIMER ----- Schedule Recording Times  
RECORD----- Record Mode Setup  
CAMERA ----- Camera Channel Setup  
SYSTEM ----- System Setup  
EVENT ----- Event List



Choose Record , and press “Enter” to enter Record menu. Following screen will be displayed.

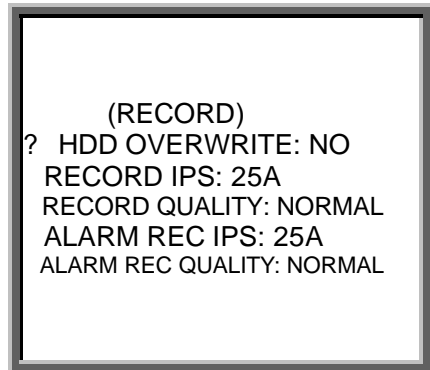

### 3.8.2 HDD OVERWRITE setup:

3.8.2.1 Press “Enter” to confirm HDD OVERWRITE setup.

3.8.2.2 Press “Up” or “Down” to choose HDD OVERWRITE.

NO: When HDD is full, unit will stop recording

YES: When HDD is full, unit will overwrite the HDD recordings

3.8.2.3 Press “MENU” to exit and confirm current operation.

3.8.2.4 Press “MENU” again to exit and close HDD OVERWRITE setup mode.

### 3.8.3 RECORD IPS setup:

3.8.3.1 Press “Enter” to confirm RECORD IPS setup.

3.8.3.2 Press “Up” or “Down” to choose IPS record speed.

NTSC- 25A, 15, 8, 4, 2, or 1

PAL- 18A, 12, 6, 3, 2, or 1

3.8.3.3 Press “MENU” to exit and confirm current operation.

3.8.3.4 Press “MENU” again to exit and close RECORD IPS setup mode.

### 3.8.4 RECORD QUALITY setup

3.8.4.1 Press "Enter" to confirm Record Quality setup.

3.8.4.2 Press "Up" or "Down" to choose Record Quality level.

BEST, HIGH, NORMAL, or BASIC

3.8.4.3 Press "MENU" to exit and confirm current operation.

3.8.4.4 Press "MENU" again to exit and close RECORD QUALITY setup mode.

### 3.8.5 ALARM REC IPS setup

3.8.5.1 Press "Enter" to confirm ALARM REC IPS setup.

3.8.5.2 Press "Up" or "Down" to choose ALARM REC IPS record speed.

NTSC- 25A, 15, 8, 4, 2, or 1

PAL- 18A, 12, 6, 3, 2, or 1

3.8.5.3 Press "MENU" to exit and confirm current operation.

3.8.5.4 Press "MENU" again to exit and close ALARM REC IPS setup mode.

### 3.8.6 ALARM REC QUALITY setup

3.8.6.1 Press "Enter" to confirm ALARM REC QUALITY setup.

3.8.6.2 Press "Up" or "Down" to choose ALARM REC QUALITY level.

BEST, HIGH, NORMAL, or BASIC

3.8.6.3 Press "MENU" to exit and confirm current operation.

3.8.6.4 Press "MENU" again to exit and close ALARM REC QUALITY setup mode.

## 3.9 CAMERA setup

Press "MENU" to enter the main menu. You will need to enter the password to access the main menu. Press "Left" or "Right" to move digit, and Press "Up" or "Down" to select number. Press "Enter" button to confirm password.

Ex.: Password: 0000 (Default: 0000)



After keying in the correct password, and confirming it by pressing the “**ENTER**” button. The screen on the right will be displayed:

SEARCH ----- Find Recordings  
 TIMER ----- Schedule Recording Times  
 RECORD----- Record Mode Setup  
 CAMERA ----- Camera Channel Setup  
 SYSTEM ----- System Setup  
 EVENT ----- Event List

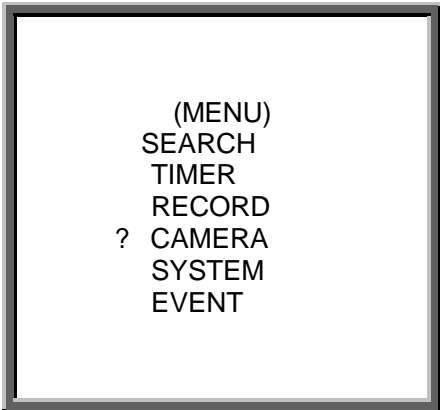

**CAMERA setup**

	TITLE	DWELL				ALARM	RECORD
?	---- 01	ON	5	5	5	LOW	EVENT
	---- 02	ON	5	5	5	LOW	EVENT
	---- 03	ON	5	5	5	LOW	EVENT
	---- 04	ON	5	5	5	LOW	EVENT
	---- 05	ON	5	5	5	LOW	EVENT
	---- 06	ON	5	5	5	LOW	EVENT
	---- 07	ON	5	5	5	LOW	EVENT
	---- 08	ON	5	5	5	LOW	EVENT
	---- 09	ON	5	5	5	LOW	EVENT
	---- 10	ON	5	5	5	LOW	EVENT
	---- 11	ON	5	5	5	LOW	EVENT
	---- 12	ON	5	5	5	LOW	EVENT
	---- 13	ON	5	5	5	LOW	EVENT
	---- 14	ON	5	5	5	LOW	EVENT
	---- 15	ON	5	5	5	LOW	EVENT
	---- 16	ON	5	5	5	LOW	EVENT

3.9.1 TITLE: Allows you to assign a title to each camera input. Initially each title is the camera’s number.

3.9.1.1 Press “Up” or “Down”: Select channel in the Channel setup

3.9.1.2 Press **ENTER**: Confirm the channel

3.9.1.3 Press “**Left**” or “**Right**”: Select the location of title (6 characters maximum)

3.9.1.4 Press “Up” or “Down”: Select the characters for display (**0~9, A~Z,-,., (,)**)

3.9.1.5 Press “MENU”: Confirm and exit the title setting

3.9.1.6 Press “MENU”: Exit the Channel setup

3.9.2 DWELL: to set up auto switching channel

3.9.2.1 Press “Up” or “Down”: Select channel in the Channel setup

3.9.2.2 Press “Enter”: Enter the channel setup

3.9.2.3 Press “ **Left** ” or “ **Right** ”: Select DWELL on the screen

3.9.2.4 Press “Up” or “Down”: Select ON/OFF on the screen

3.9.2.5 Press “MENU”: Confirm and exit the dwell setting

3.9.2.6 Press “MENU”: Exit the channel setup

### 3.9.3 (**Brightness**) / (**Contrast**) / (**Color**): video adjustment of each channel

3.9.3.1 Press “Up” or “Down”: Select channel in the Channel setup

3.9.3.2 Press “**ENTER**” Enter the channel setup

3.9.3.3 Press “ **Left** ” or “ **Right** ”: Select brightness/contrast/color on the screen

3.9.3.4 Press “Up” or “Down”: Set up **0~9** on the screen.

3.9.3.5 Press “**MENU** ”: Confirm and exit the brightness/contrast/color setting.

3.9.3.6 Press “**MENU**”: Exit the channel setup

### 3.9.4 ALARM

3.9.4.1 Press “Up” or “Down”: Select channel in the Channel setup

3.9.4.2 Press “**ENTER**” to Enter the channel setup

3.9.4.3 Press “ **Left** ” or “ **Right** ”: Select ALARM on the screen

3.9.4.4 Press “Up” or “Down”: Select LOW/OFF/HIGH for alarm polarity

3.9.4.5 Press “**MENU**”.” Confirm and exit the alarm setting.

3.9.4.6 Press “**MENU**”.” Exit the channel setup

### 3.9.5 RECORD

3.9.5.1 Press “Up” or “Down”: Select channel in the Channel setup

3.9.5.2 Press “**ENTER**”.: Enter the Channel setup

3.9.5.3 Press “ “Left” or “Right”: Select Record on the screen.

3.9.5.4 Press “Up” or “Down”: Select record method as below (Unit will only record the channel which has been set up for **EVENT/ NORMAL/ OFF**)

**EVENT**: when an alarm input is triggered, unit will record alarming channel more frequently. For example: normal record method is 1-2-3-4-5-.....-16. In Event mode, when CH01 is triggered, the record method will become 1-2-1-3-1-4-1-5-...-16.

**NORMAL**: when external alarm is on, unit will record normally as set up.

**OFF**: DMR will not record

3.9.5 Press “MENU”: Confirm and exit the record setting

3.9.6 Press “MENU”: Exit the channel setup

## 3.10 **MOTION DETECTION setup**

3.10.1 Press “MENU” to enter the menu set up, then “ **Down**” to **CAMERA** setup, Press “ENTER” twice to enter the  Motion Detection Setup .

3.10.2 Each screen displays the current camera picture overlaid with the motion targets (as Figure 1). You can push the button “Left” or “Right”, “Up” or “Down” to adjust motion detection in **ON** or **OFF**.

3.10.3 The targets on each motion setup can be turned to ON or OFF individually by row. To set up targets, using the following front panel buttons:

3.10.3.1 Press “**ENTER**” to confirm the channel

3.10.3.2 Press “**ENTER**” to enter motion mode

3.10.3.3 ? **Up** -- moves the target cursor up one row at a time.

3.10.3.4 ? **Down** -- moves the target cursor down one row at a time.

3.10.3.5 ? **Left** -- moves the target cursor left one column at a time.

3.10.3.6 ? **Right** -- moves the target cursor right one column at a time.

3.10.3.7 Press “**ENTER**” to turn the target cursor ON

Press “**ENTER**” again to turn the target cursor OFF

3.10.3.8 **Camera Select (1-15)** — toggles the corresponding target on the cursor line ON or OFF. (Figure 1) There are only 15 targets in a row, therefore; only Camera Selected (1-15) can be operated.



3.10.3.9 **Zoom** – turns all targets in the current row ON or OFF. (Figure 1-2)

3.10.3.10 **PIP** – turns all targets on the screen ON or OFF. (Figure 1-3)

3.10.4 Press “ **SLOW** “ button to setup the Sensitivity list **up to 25** Press “ **REC** “ button to setup the Sensitivity list **down to 000**. Sensitivity value is related to motion and brightness change. Low value (as 001) means higher sensitivity on motion and brightness change. High value (as 255) means lower sensitivity on motion and brightness change. User can choose the suitable sensitivity value in different locations. The default value is set on 32.

#### **Note:**

If Motion Detection is set, and activated, there are two actions as follows:

1). **Live Video** - The motion detected camera(s) will be scanned more frequently, if the Video set up for 16 cameras, the sequence to scan the cameras is from 1st, 2nd, 3<sup>rd</sup>, through 16 cameras. If motion is detected on Camera #1, the sequence to scan #1 camera will be more frequently. It will scan as 1st, 2nd, 1st, 3rd, 1st, 4th..1st, 16th. And CH 1 will show the motion icon . If the 2nd camera and 3rd camera are activated, they will be scanned as 1st, 2nd, 3rd, 2nd, 2nd, 3rd, 3rd, 2nd, 3rd, 4th, 2nd, 3rd. CH2 and CH3 will show the motion icon  until motion stops.

2). **Recorded Video** - Video will be recorded for the motion detected cameras the same fashion as Live video. If Motion Detection is set and activated, the DVR will automatically start recording when motion is detected. Motion detection recording is further described in section

4.2 as Alarm Record. Alarm Record is defined as a MOTION DETECTION trigger or an external IO trigger (see ALARM INPUTS section 3.3 for hard wired alarm inputs)

Figure 1 **MOTION DETECTION SETUP**

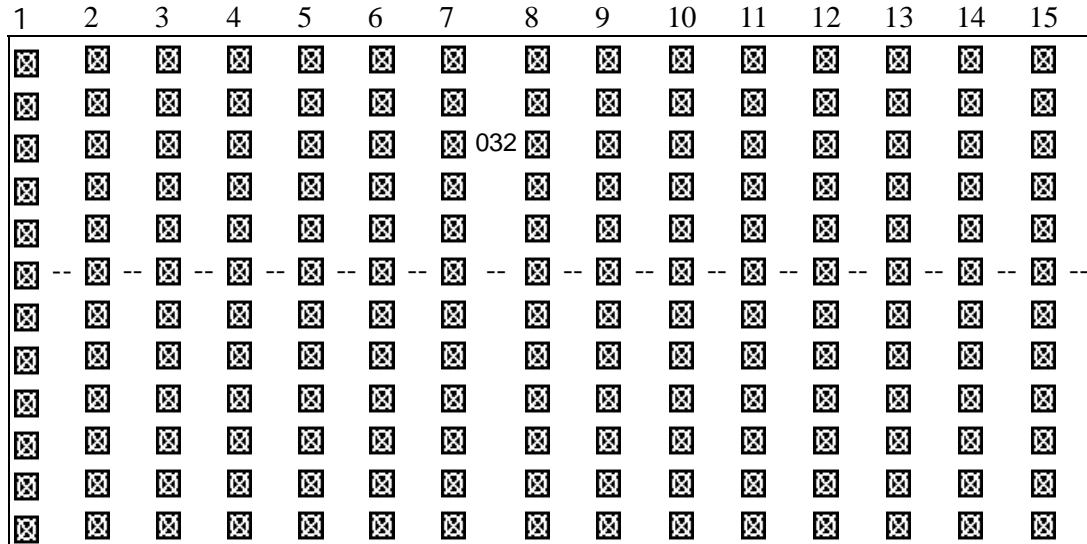

Figure 1-1 **MOTION DETECTION SETUP – 1~16**

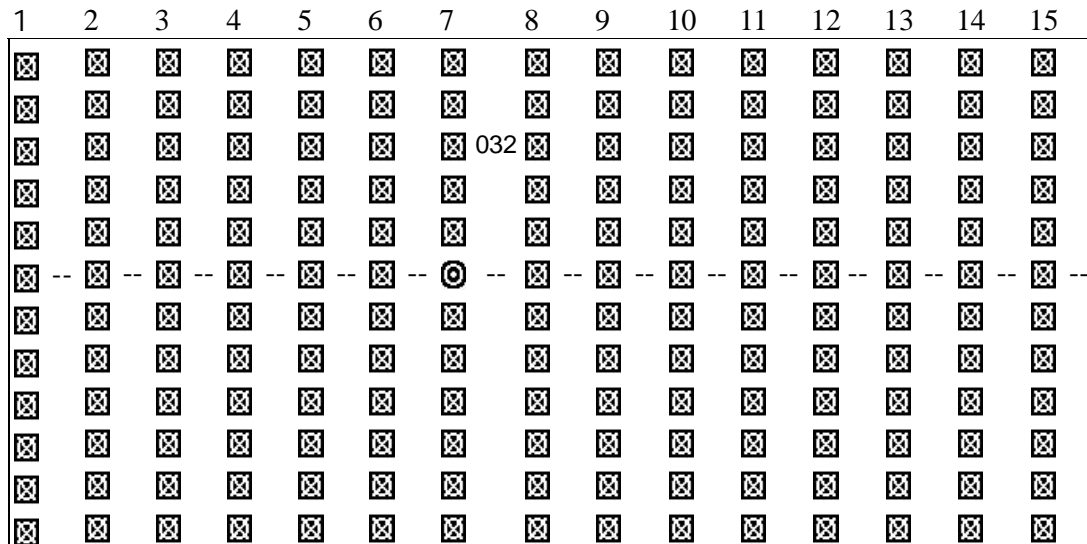

Figure 1-2 **MOTION DETECTION SETUP – LINE**

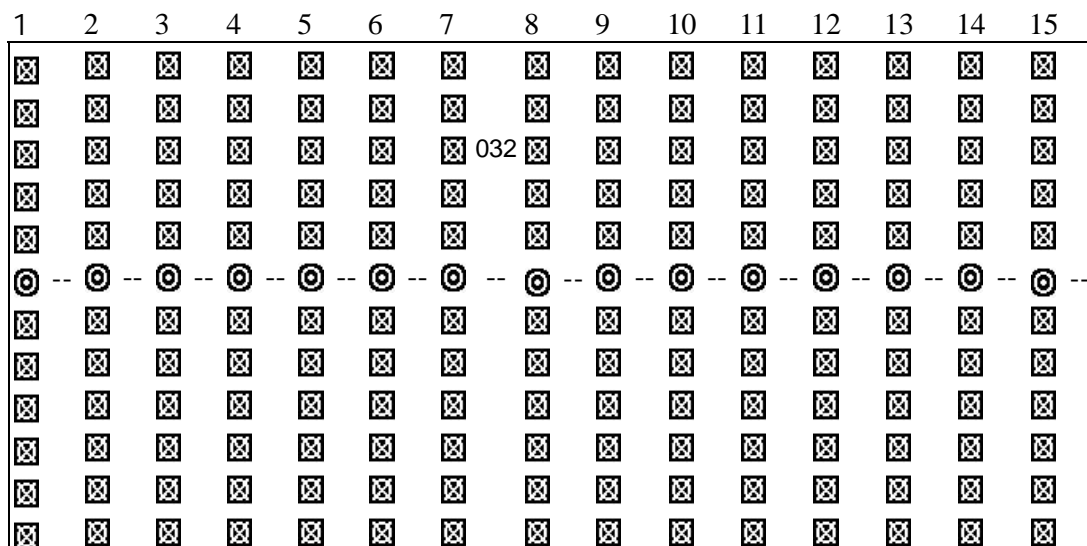
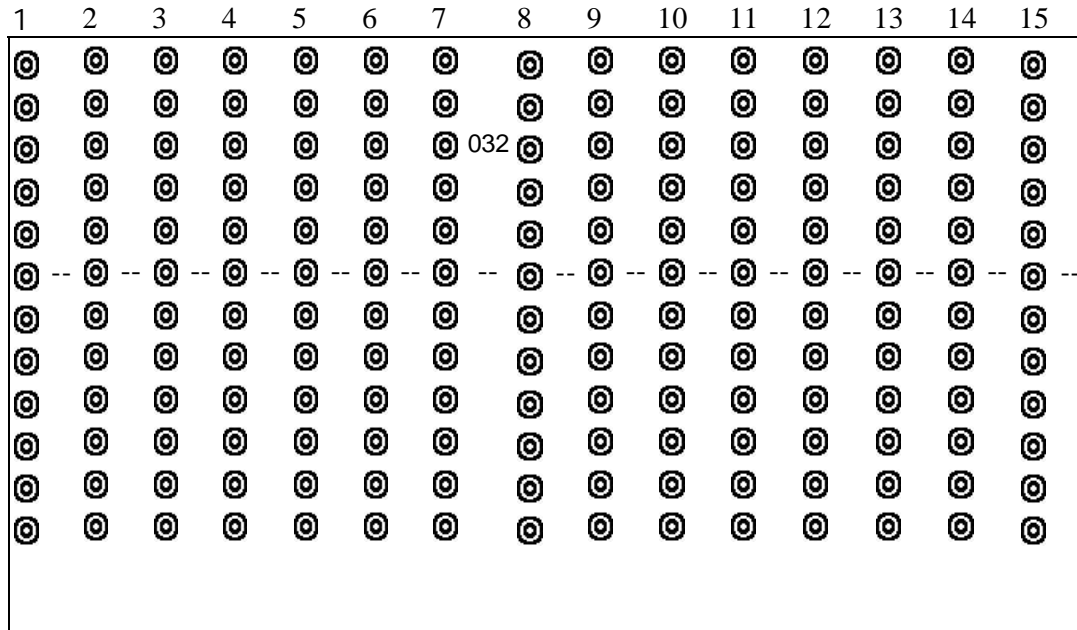

Figure 1-3 MOTION DETECTION SETUP – ALL



### 3.11 Event

#### 3.11.1 Enter "Event" list

Press **"MENU"** to enter the main menu. You will need to enter the password to access the main menu. Press **"Left"** or **"Right"** to move digit, and Press **"Up"** or **"Down"** to select number. Press the **"ENTER"** button to confirm password.

Ex.: Password: 0000 (Default: 0000)



After keying in the correct password, and confirming it by pressing the **"ENTER"** button. The screen on the right will be displayed:

SEARCH ----- Find Recordings  
 TIMER ----- Schedule Recording Times  
 RECORD----- Record Mode Setup  
 CAMERA ----- Camera Channel Setup  
 SYSTEM ----- System Setup  
 EVENT ----- Event List



Press “**ENTER**” to confirm Full List, the screen on the right will be displayed.

Press ” “Up” or “Down” to choose wanted recorded event (Only 8 recorded events will be shown on a single page). Press “Up” or “Down” to change the pages.

Press “**ENTER**” to Play selected recorded video

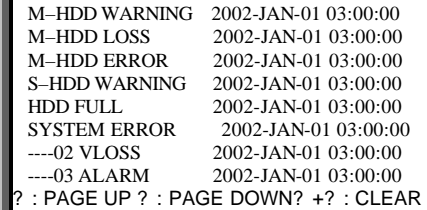

M-HDD WARNING	2002-JAN-01 03:00:00
M-HDD LOSS	2002-JAN-01 03:00:00
M-HDD ERROR	2002-JAN-01 03:00:00
S-HDD WARNING	2002-JAN-01 03:00:00
HDD FULL	2002-JAN-01 03:00:00
SYSTEM ERROR	2002-JAN-01 03:00:00
---02 VLOSS	2002-JAN-01 03:00:00
---03 ALARM	2002-JAN-01 03:00:00
? : PAGE UP ? : PAGE DOWN? +? : CLEAR	

M-HDD WARNING: Master HDD may have a failure.

M-HDD LOSS: Master HDD does not exist. Use the slave HDD if installed

M-HDD ERROR: Master HDD may have a writing error

S-HDD WARNING: Slave HDD may have a failure

S-HDD LOSS: Slave HDD does not exist. Use the master HDD if installed

S-HDD ERROR: Slave HDD may have a writing error

HDD FULL: HDD is full

SYSTEM ERROR: System may have a failure

---02 VLOSS: Channel: 2 Video loss

---03 ALARM: Channel: 3 External I/O Alarm has triggered

POWER RESTORE: Power restore

## 4. Operation

### 4.1 Power on

Before powering on the unit, make sure the HDD has been locked, and the POWER LED is red. After pressing the POWER button, POWER LED will turn to an orange color, then all other LEDs will turn to a RED color except the LED for HDD. The OSD screen will display “HDD Detecting”. Power on time will take approximately 15 to 20 seconds. If the HDD is set as Master, the screen will display “MASTER HDD CONNECTED”. If HDD is set as Slave, the screen will display “SLAVE HDD CONNECTED”. In order to shorten the power on running time, we suggest set the HDD as Master. You can set up the HDD to be a Master or Slave with the jumper setting on the HDD.

After the DMR has initialized, the POWER LED will turn to a green color.

### 4.2 Recording

Your DMR offers a variety of flexible recording modes. You can set it up to record continuously, by scheduled time, or by triggered events. You can also adjust the recording speed and resolution by selecting MENU and System before recording. If power is interrupted during the record mode, the unit will return to the record mode after power returns.

There are 3 record modes for this DMR: Alarm Record, Timer Record, and Manual Record. All record Modes are described below.

#### 4.2.1 Alarm Record

When DMR is triggered by alarm input, it will start to record immediately. Following screen will be displayed.

A : Alarm trigger  
OW : HDD Over Write  
032GB (Shown at the OW location means)  
32 GB HDD are left for video recording. (1 HDD installed)  
001GB: (Shown at the OW location means)  
032GB  
32 GB left in slave HDD and 1 GB left in master HDD for video recording. (2 HDD installed)

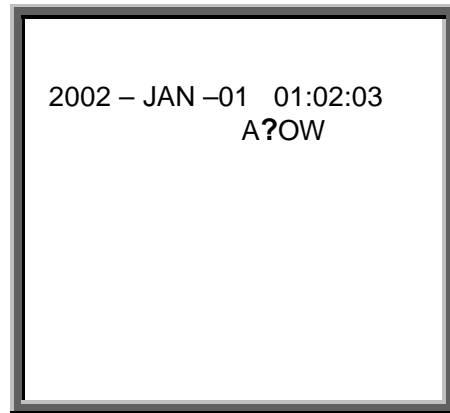

#### 4.2.2 Timer Record

DMR will follow Timer setup to record. Recording speed and quality are entered in the recording mode setup in the main menu.

The screen on the right will be displayed.

T : Timer record  
OW: HDD Over Write  
032GB (Shown at the OW location means)  
32 GB HDD are left for video recording. (1 HDD installed)  
001GB: (Shown at the OW location means)  
032GB  
32 GB left in slave HDD and 1 GB left in master HDD for video recording. (2 HDD installed)

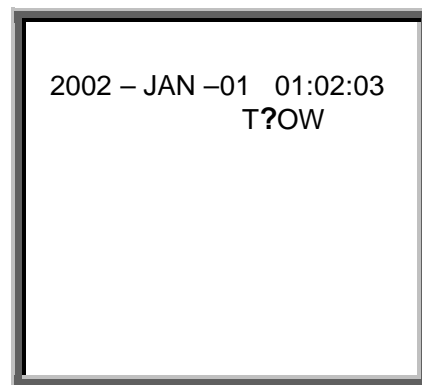

#### 4.2.3 Manual Record

You can press "REC" to start recording immediately. Recording speed and quality are entered in the recording mode setup in the main menu.

Following screen will be displayed.

OW: HDD Over Write  
032GB (Shown at the OW location means)  
32 GB HDD are left for video recording. (1  
HDD installed)  
001GB: (Shown at the OW location means)  
032GB  
32 GB left in slave HDD and 1 GB left in  
master HDD for video recording. (2 HDD  
installed)

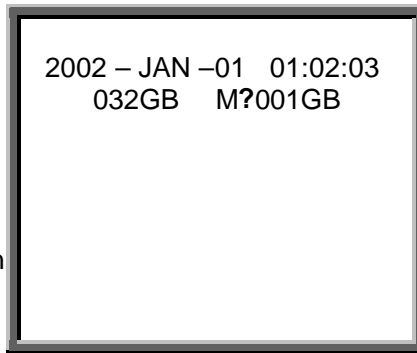

### 4.3 Camera Select (1-16)

Press Camera Select (1-16) to select a camera to display in full screen mode.

### 4.4 Select

This feature allows the user to get the ideal camera viewing location.

4.4.1. Press    button to show different viewing formats.

4.4.2 Press “ **Select** ” then “Left” or “Right” button to locate the desired position.

4.4.3 Press “ **Camera Select (1-16)** ” to select the appointed camera.

4.4.4 Press “MENU” to exit.

### 4.5 Picture in Picture (PIP)

Press PIP  button to enter PIP display screen. The PIP format displays a full screen “background” picture with a 1/16 size screen ‘insert”.

4.5.1 Press  button to display the last selected PIP mode.

4.5.2 Press “ **Select** ” then “Left” or “Right” button to move the insert screen.

4.5.3 Press “MENU” to exit

### 4.6 Zoom

Press ZOOM button to enlarge the display of the main camera. Unit displays zoom picture on main view with a small window inserted. The inserted window contains a movable 1/4 view size of another selected camera.

4.6.1 Press the appointed “ **Camera Select (1-16)** ”.

4.6.2 Press “ **Zoom** ” button to be zoom mode.

4.6.3 Press the “**Zoom** ” button again to move the zoom pointer.

4.6.4 Press “MENU” to exit.

## **4.7 Play**

Press “ **PLAY** ” the DMR will enter the Play mode; it will show the last recording.

### **4.7.1 Fast Forward (F.F.) & Fast Rewind (F.R.)**

4.7.1.1 Press “ **PLAY** ” and press “ ? ? ” for fast forward search. Press “ ? ? ” once for 2X speed, press “ ? ? ” twice to for 4X speed. The maximum search speed is 32X.

4.7.1.2 Press “ **PLAY** ” then Press “ ? ? ” for fast rewind search. Press “ ? ? ” once for 2X speed, press “ ? ? ” twice to for 4X speed. The maximum search speed is 32X.

### **4.7.2 Slow Forward (S.F.) & Slow Rewind (S.R.)**

4.7.2.1 Press “ **PLAY** ” then press “ **SLOW** ” for 1/2 X slow forward speed, Press “ ? ? ” once for 1/4 slow forward, press “ ? ? ” twice for 1/8 X speed, ....the minimum slow speed is 1/32 X.

4.7.2.2 Press “ **PLAY** ” then press “ **SLOW** ” then press, “ ? ? ” for 1/2 X slow rewind speed, press “ ? ? ” twice for 1/4 X speed, ....the minimum slow speed is 1/32 X.

4.7.3 Pause: Press “ **PLAY** ” then press “ **PAUSE** ”, it will pause the screen

4.7.4 Stop: Press “ **STOP** ” under any circumstance, it will return the DMR to live monitoring mode.

### **4.7.5 Image jog dial**

4.7.5.1 Press “ **PLAY** ” then press “ **PAUSE** ”, this will pause playback. Press “ ? ? ” for single image forward play, or “ ? ? ” for reverse image play. Images are shown one by one while continuously pressing the “ ? ? ” button or “ ? ? ” button.

## **4.8 VIDEO LOSS**

Screen will display “  ” if a video input is disconnected.

## **4.9 KEY LOCK WITH PASSWORD**

To prevent unauthorized operation of this recorder, press the “MENU” and “Enter” keys at same time. The screen will display “KEY LOCK”, and all operation buttons on the front panel will be locked.

To unlock, press the “MENU” and “ENTER “ keys again at the same time, key in your password (Default: 0000) and press “Enter”, the screen will display “KEY UNLOCK ” allowing the front panel buttons to work once again.

## 5. Trouble shooting & Appendix

### 5.1 Trouble shooting

The table below describes some typical problems and their remedies.

PROBLEM	SOLUTION
HDD Not Found	<ul style="list-style-type: none"> <li>☞ Insert HDD</li> <li>☞ Use the Key to lock the HDD Cartridge and press any key</li> </ul>
No power	<ul style="list-style-type: none"> <li>☞ Check power cord connections.</li> <li>☞ Confirm that there is power at the outlet.</li> </ul>
No response from any button	<ul style="list-style-type: none"> <li>☞ Check display for Key Lock mode.</li> <li>☞ Press <b>"MENU"</b> &amp; <b>"ENTER"</b> at same time to exit Key Lock mode.</li> </ul>
No recorded video	Check that the HDD is installed properly.
Timer Record enable does not work	Check if the Record Enable is set to YES
No live video	<ul style="list-style-type: none"> <li>☞ Check camera video cable and connections.</li> <li>☞ Check monitor video cable and connections.</li> <li>☞ Plug camera(s) directly into monitor for testing</li> <li>☞ Check camera(s) lens setting.</li> </ul>

### 5.2 Compatible HDD brands

Manufacturer	Model	Capacity	Rotation
HITACHI	Deskstar 180 GXP (120 GB)	120GB	7200rpm
IBM	Deskstar 120GXP (40GB)	40GB	7200 rpm
IBM	Deskstar 60GXP IC35I060	60GB	7200 rpm
IBM	Deskstar 120GXP (80GB)	80GB	7200 rpm
IBM	Deskstar 120GXP (120GB)	120GB	7200 rpm
Maxtor	DiamondMax 536DX(60GB) 4W060H4	60GB	7200rpm

Maxtor	DiamondMax Plus 9, Model#6Y120L	120GB	7200 rpm
Seagate	Barracuda ATA IV, ST340016A	40GB	7200 rpm
Seagate	Barracuda ATA V, ST3120023A	120GB	7200 rpm
Seagate	Barracuda ATA IV, ST380021A	80GB	7200rpm
Western Digital	Caviar WD400BB-00BSA0	40GB	7200 rpm
Western Digital	Caviar WD400EB-00CPF0	40GB	5400 rpm
Western Digital	Caviar WD1200BB-00CAA1	120GB	7200rpm

## Security Labs Limited Warranty

Security Labs, Inc. warrants that if a Security Labs product proves to be defective in material or workmanship under normal usage, Security Labs will provide without charge to the consumer, parts and/or labor necessary to remedy the defect for the period of ONE YEAR from the date of purchase. The warranty period commences on the date that the product is purchased by the consumer. Any implied warranty is also limited to the duration above.

**THIS WARRANTY DOES NOT COVER THE FOLLOWING: FLUCTUATIONS IN THE POWER SOURCE OR LIGHTNING-RELATED DAMAGE; ATTACHED OR UNATTACHED ACCESSORIES; COSMETIC PARTS SUCH AS KNOBS AND ACCESS DOORS; CABINET DAMAGE, INCLUDING DAMAGE IN TRANSIT; ACCIDENTAL DAMAGE; MISUSE; ABUSE; UNAUTHORIZED PARTS USAGE OR REPAIRS; RECEPTION PROBLEMS DUE TO INADEQUATE SIGNAL; UNAUTHORIZED INTERNAL CONTROL OF ADJUSTMENTS; INSTALLATION; ADJUSTMENT OF CONSUMER CONTROLS; OR ANY OTHER USE OF THE PRODUCT OTHER THAN THAT SPECIFICALLY PRESCRIBED IN THE OWNER'S MANUAL. THIS WARRANTY APPLIES TO PRODUCT SOLD AS NEW AND NOT REMANUFACTURED, RECERTIFIED, OR B STOCK PRODUCTS.**

**SECURITY LABS, INC. DOES NOT ASSUME LIABILITY FOR ANY VIOLATION OF PRIVACY FROM ILLEGAL RECORDINGS MADE ON THIS UNIT. THE USER/OWNER ASSUMES FULL LIABILITY FOR ANY AND ALL RECORDINGS MADE FROM THIS UNIT IN A SECURITY OR SURVEILLANCE OPERATION OR IN ANY OTHER USE. SECURITY LABS IS NOT RESPONSIBLE FOR RECORDINGS THAT VIOLATE LAWS OR THAT MAY PROVE OFFENSIVE OR TEND TO INCRIMINATE ANOTHER INDIVIDUAL. LOCAL, STATE, AND FEDERAL LAWS MUST BE OBSERVED REGARDING ALL RECORDINGS.**

To obtain warranty service, the consumer must provide the product along with evidence that will positively identify the date that the product was purchased from Security Labs or an authorized Security Labs product representative, dealer, retailer, or distributor. Prior to shipment, a RETURN AUTHORIZATION must be obtained from SECURITY LABS; this will assist us in more efficient service on your unit, and possibly avoid shipment if the adjustment can be made over the phone. If shipment is made, the cost for postage, insurance and shipping of the product is the responsibility of the owner.

**SECURITY LABS' OBLIGATION UNDER THIS WARRANTY SHALL BE TO REPLACE SUCH PARTS AND PROVIDE LABOR AS STATED. SECURITY LABS WILL NOT BE LIABLE FOR ANY LOSSES OR INCONVENIENCES DIRECT OR INDIRECT, OR CONSEQUENTIAL PROPERTY DAMAGES.**

To obtain a warranty return authorization number, contact Security Labs' Customer Service at:

SECURITY LABS, INC.  
15540 HERRIMAN BLVD.  
NOBLESVILLE, IN 46060  
CUSTOMER SERVICE  
1-800-774-0284  
ONLINE: [www.security-labs.com](http://www.security-labs.com).